

# Comparison of Retention Modeling in ion Chromatography by Using Multiple Linear Regression and Artificial Neural Networks

---

**Bolanča, Tomislav; Cerjan-Stefanović, Štefica; Srečnik, Goran; Debeljak, Željko; Novič, Milko**

*Source / Izvornik:* **Separation Science and Technology, 2005, 40, 1333 - 1352**

**Journal article, Published version**

**Rad u časopisu, Objavljena verzija rada (izdavačev PDF)**

<https://doi.org/10.1081/SS-200052816>

*Permanent link / Trajna poveznica:* <https://um.nsk.hr/um:nbn:hr:239:911779>

*Rights / Prava:* [Attribution 3.0 Unported/Imenovanje 3.0](#)

*Download date / Datum preuzimanja:* **2024-07-23**



*Repository / Repozitorij:*

[Repository UHC Osijek - Repository University Hospital Centre Osijek](#)



## Comparison of Retention Modeling in Ion Chromatography by Using Multiple Linear Regression and Artificial Neural Networks

Tomislav Bolanča , Štefica Cerjan-Stefanović , Goran Srečnik , Željko Debeljak & Milko Novič

To cite this article: Tomislav Bolanča , Štefica Cerjan-Stefanović , Goran Srečnik , Željko Debeljak & Milko Novič (2005) Comparison of Retention Modeling in Ion Chromatography by Using Multiple Linear Regression and Artificial Neural Networks, Separation Science and Technology, 40:6, 1333-1352, DOI: [10.1081/SS-200052816](https://doi.org/10.1081/SS-200052816)

To link to this article: <https://doi.org/10.1081/SS-200052816>



Published online: 15 Feb 2007.



Submit your article to this journal [↗](#)



Article views: 68



View related articles [↗](#)



Citing articles: 3 View citing articles [↗](#)

# Comparison of Retention Modeling in Ion Chromatography by Using Multiple Linear Regression and Artificial Neural Networks

**Tomislav Bolanča and Štefica Cerjan-Stefanović**

University of Zagreb, Faculty of Chemical Engineering and Technology,  
Department for Analytical Chemistry, Zagreb, Croatia

**Goran Srečnik**

PLIVA, Pharmaceutical Industry, Research and Development, Zagreb,  
Croatia

**Željko Debeljak**

Clinical Hospital Osijek, Department of Medicinal Biochemistry, Osijek,  
Croatia

**Milko Novič**

National Institute of Chemistry, Laboratory for Analytical Chemistry,  
Ljubljana, Slovenia

**Abstract:** The aim of this work is comparison of the prediction power of multiple linear regression and artificial neural networks retention models for inorganic anions (fluoride, chloride, nitrite, sulfate, bromide, nitrate, and phosphate) in suppressed ion chromatography with isocratic elution. Relations between ion chromatographic parameters (eluent flow rate and concentration of  $\text{OH}^-$  in eluent) and retention time of particular anion are described with unique mathematical function obtained by multiple linear regression and with a three-layers feed-forward artificial neural network. The artificial neural network was trained with a Levenberg-Marquardt

Received 5 August 2004, Accepted 7 January 2005

Address correspondence to Tomislav Bolanča, University of Zagreb, Faculty of Chemical Engineering and Technology, Department for Analytical Chemistry, Marulićev trg 20, 10000, Zagreb, Croatia. Fax: 385 1 4597 250; E-mail: [tbolanca@fkit.hr](mailto:tbolanca@fkit.hr)

batch error back propagation algorithm. It is shown that the multiple linear regression retention model has lower, but still very satisfactory, predictive ability. Due to its complexity, the artificial neural network must still be regarded as a more complicated technique. That indicates multiple linear regression as a method of choice for retention modeling in the case of ion chromatographic analysis with isocratic elution.

**Keywords:** Ion chromatography, retention modeling, multiple linear regression, artificial neural networks

## INTRODUCTION

Ion chromatography (IC) is a widely used technique and its methodology and applications are described in several books (1, 2) and reviews (3–8). Method development in ion chromatography is relatively complex owing to the great number of parameters that influence separation, i.e., concentration and type of eluent ions, eluent flow rate, and temperature. The optimal separation in ion chromatography can be achieved by using computer-assisted optimization procedures that are based on a retention model providing a mathematical relationship for calculating the retention time of the analyte under differing conditions. The predictive ability of the retention model is the most important consideration in the success of the separation optimization procedure.

Two types of retention models can be identified, namely, theoretical (hard modeling) (9–19) and empirical (soft modeling) (20–23). Theoretical models are derived totally from theory and invariably require at least knowledge of parameters relating to the analyte, stationary phase, and eluent before calculation of the analyte retention factor is possible. Empirical models are not based on theoretical explanations of the physical and chemical interactions. They concentrate on finding the best relation between controlled and measured parameters. The main advantages of empirical modeling are the accuracy and speed of the algorithms, while the main disadvantage is that there is no theoretical explanation of occurred interactions.

Comparison of a series of mathematical models of retention in ion chromatography with special emphasis on the separation of anions were discussed earlier (9, 10, 21). The linear solvent strength model in both its multiple eluent species forms, the dominant equilibrium approach, the competing ion effective charge approach, the Hoover model, the dual eluent species model, the Kuwamoto model, the extended dual eluent species model, the multiple species eluent/analyte model, and the empirical end of points model were examined. It was shown that the more complex the model is, the more improved the prediction is, but none of the models is satisfactory for implementation in software. An empirical end of points model in which linear relationship is assumed between logarithm of capacity factor ( $\log k$ )

and  $\log$  (eluent) but the slope, which is determined experimentally, gave the best performance. A comparison between empirical retention models in which the relationship between  $\log k$  and the volume fraction of the organic modifier in the eluent as well as  $1/k$  and volume fraction of the organic modifier in micellar liquid chromatography was published (24, 25). It is shown that the retention model relating  $1/k$  and volume fraction of the organic modifier gave best performance.

The use of the machine learning methods for empirical retention modeling represents the fundamental research issue. The ability of a computer to learn independently is a recognized manifestation of intelligence and offers the potential to build intelligent systems more efficiently. There are many different approaches one can take to develop a method of machine learning. Techniques that are currently popular include artificial neural networks (ANN), genetic algorithms (GA), and induction (26). Retention models obtained by using artificial neural networks have very good predictive ability, but described algorithms are complex and require more than basic knowledge about artificial neural network theory (20, 22, 23). That is why it is essential to develop more user friendly mathematical methods to model ion chromatographic retention time without a significant decrease in predictive ability.

The objective of this work is the development of a simple and rapid methodology for empirical retention modeling of seven inorganic anions (fluoride, chloride, nitrite, sulfate, bromide, nitrate, and phosphate) in suppressed ion chromatography with isocratic elution. Relations between ion chromatographic parameters (eluent flow rate and concentration of  $\text{OH}^-$  in eluent) and retention time of particular anions are described with unique mathematical functions and with artificial neural networks. Coefficients of the functions were found by using multiple linear regressions. The unique technique of experimental data selection for modeling set was used, allowing improvement of multiple linear regression and artificial neural network models' prediction power. Prediction power of retention models is validated with an external set of experimental data points and compared. It is shown that the developed multiple linear regression retention model offers less complex and rapid alternative for retention modeling with fairly good predictive ability.

## EXPERIMENTAL

### Reagents

Stock solutions of fluoride (1.0000 g/L), chloride (1.0000 g/L), nitrite (1.0000 g/L), sulfate (1.0000 g/L), bromide (1.0000 g/L), nitrate (1.0000 g/L), and phosphate (1.0000 g/L) were prepared from the air-dried (at 105°C) salts of individual anions of p.a. grade (Merck, Darmstadt, Germany). Working standard solutions of fluoride (2.00 mg/L), chloride (5.00 mg/L),

nitrite (10.00 mg/L), sulfate (10.00 mg/L), bromide (20.00 mg/L), nitrate (20.00 mg/L), and phosphate (30.00 mg/L) were prepared by measuring the appropriate volume of stock solution of the individual anion onto a 100 mL volumetric flask, which was later filled to the mark with Milli-Q water. Working eluent solutions were prepared online by appropriate dilution of KOH with Milli-Q water. An  $18\text{ M}\Omega\text{cm}^{-1}$  water (Millipore, Bedford, MA, USA) was used for dilution in all cases.

## Apparatus

The Dionex DX500 chromatography system (Dionex, Sunnyvale, CA, USA) equipped with quaternary gradient pump (GP50), eluent generator module (EG40), chromatography module (LC25), and detector module (ED40) was used in all experiments. Separation and suppressor columns used were the Dionex IonPac AG15 ( $4 \times 50$  mm) guard column, the IonPac AS15 ( $4 \times 250$  mm) separation column, and the ASRS-ULTRA-4 mm suppressor column, working in recycle mode, respectively. The sample-loop volume was  $50\ \mu\text{L}$ . The eluent flow rates were 1.00 to 1.95 mL/min, and concentrations of  $\text{OH}^-$  in eluent were 25.00 to 60.00 mmol/L. The whole system was computer controlled through PeakNet 5.1 software. The applied chromatography setup is schematically presented in Fig. 1.

The data for further evaluation were obtained by exporting the appropriate chromatograms into ASCII files. ASCII data files were further evaluated using a Microcal Origin (Microcal Software, USA) software package.

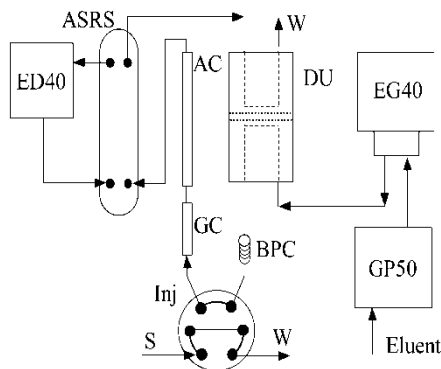

**Figure 1.** The scheme of the DX500 ion chromatography system with built-in electro-dyalitic KOH generator (EG40). GP50, quaternary gradient pump; EG40, eluent generator; DG, degas module; Inj, injector; GC, guard column (AG15); AC, analytical column (AS15), ASRS, suppressor column (ASRS-ULTRA, recycle mode); BPC, back-pressure coil; ED40, electrochemical detector (conductivity mode); S, sample; eluent,  $\text{OH}^-$ , and W, waste.

## Experimental Design

The experimental design was planned to describe the chromatographic behavior in a multidimensional space: retention time vs. eluent flow rate and concentration of  $\text{OH}^-$  in eluent. The eluent flow rate varied in range from 1.00 to 1.95 mL/min and the concentration of  $\text{OH}^-$  in eluent varied from 25.00 to 60.00 mmol/L. The 128 experimental data points were obtained. The experimental data points are logarithmically ( $\log_{10}$ ) transformed before modeling, because of the heteroscedastic nature of the retention times variance. That provides the homogeneous variance in output of the multiple linear regression retention model (retention times of fluoride, chloride, nitrite, sulfate, bromide, nitrate, and phosphate).

The independent set for modeling (16 experimental data points, Table 1) and for validating (112 experimental data points) were selected to cover the whole design space. For that purpose the design space (128 experimental data points) was divided into 16 subspaces from which one experimental data point was chosen for the modeling set from each subspace by using random function. The remaining 112 experimental data points were used as a validation set. Figure 2 presents the experimental design model where the 16 experimental data points used for modeling set are marked.

## Retention Modeling

Relations between retention times of a particular anion [ $f(x)$ , i.e., retention time of: fluoride, chloride, nitrite, sulfate, bromide, nitrate, and phosphate] and ion chromatographic parameters ( $x_1$  = eluent flow rate and  $x_2$  = concentration of  $\text{OH}^-$  in eluent) were described with the unique mathematical function:

$$f(x) = a_0 + a_1x_1 + a_2x_2 + a_3\frac{1}{x_1} + a_4\frac{1}{x_2} + a_5x_1x_2 \quad (1)$$

The main advantages of the proposed model are the inverse proportional relation between retention time and eluent flow and retention time and concentration of  $\text{OH}^-$  in eluent. The presented equation is proposed on the basis of retention modeling experiences in micellar liquid chromatography (24, 25). The retention model with one function that takes into account all seven inorganic anions is very hard to achieve. Therefore, retention times of inorganic anions were modeled separately. Constants  $a_0$ ,  $a_1$ ,  $a_2$ ,  $a_3$ ,  $a_4$ , and  $a_5$  were determined in order to reduce deviation of the model by using multiple linear regression.

The neural network used in this paper is the feed-forward back-propagation neural network. The input layer consists of the two nodes

**Table 1.** Experimental data points used for determination of retention model function coefficients by using multiple linear regression and artificial neural network retention model training calculations

Eluent flow rate/mL/min	c(OH <sup>-</sup> ) in eluent/ mmol/L	Fluoride/ min	Chloride/ min	Nitrite/min	Sulfate/min	Bromide/ min	Nitrate/min	Phosphate/min
1.55	25	4.53	7.52	9.02	15.43	15.93	17.48	47.53
1.4	30	4.6	7.53	9.03	13.48	15.55	17.62	35.45
1.15	32	5.05	8.25	9.87	14.12	16.85	19.03	34.53
1.65	32	4.15	6.35	7.45	10.37	12.22	13.67	24.28
1.3	34	4.67	7.47	8.9	12.02	15.12	17.05	28.18
1.75	36	3.9	5.72	6.63	8.38	10.57	11.78	17.23
1.3	38	4.57	7.08	8.37	10.32	13.97	15.68	21.65
1.15	40	4.82	7.4	8.72	10.37	14.35	16.07	20.42
1.1	42	4.92	7.63	9.05	10.45	15.1	16.93	20.33
1.3	42	4.48	6.77	7.95	9.08	13.03	14.58	17.23
1.75	44	3.77	5.28	6.03	6.65	9.28	10.27	11.22
1.6	46	3.97	5.67	6.55	7	10.33	11.43	11.7
1.3	50	4.35	6.3	7.3	7.48	11.62	11.98	12.93
1	55	4.62	4.97	7.3	8.47	12.95	13.68	15.23
1.5	55	3.95	5.43	6.17	6.17	8.73	9.47	10.43
1.4	60	4.08	5.62	6.05	6.38	8.28	9.77	10.73



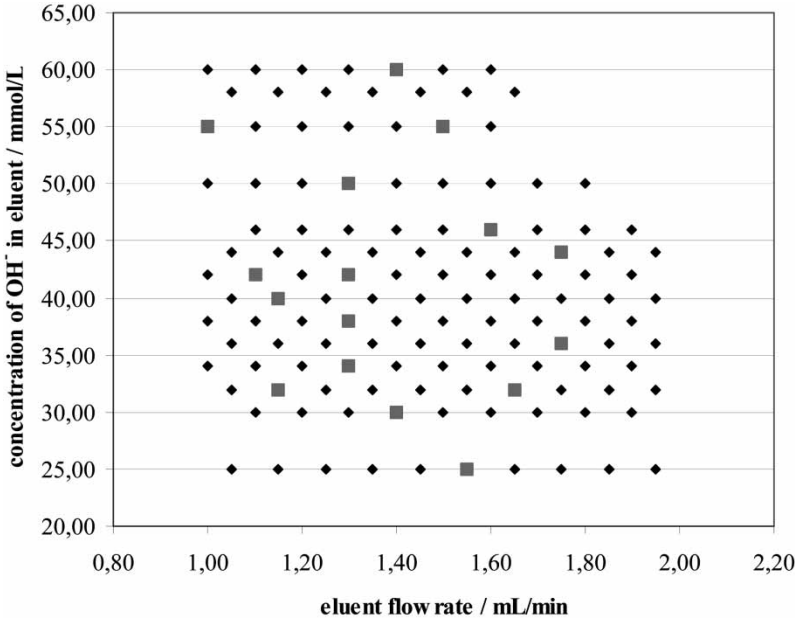

**Figure 2.** Design of 128 experimental data points: concentration of OH<sup>-</sup> in eluent vs. eluent flow rate. The 16 experimental data points used for retention modeling are marked.

representing eluent flow rate and concentration of OH<sup>-</sup> in eluent. The output layer consists of seven nodes representing retention times of the seven inorganic anions (fluoride, chloride, nitrite, sulfate, bromide, nitrate, and phosphate).

The neural network consists of one hidden layer of nodes. Two different transfer functions were used. The hyperbolic tangent sigmoid transfer function was used for computation of hidden layer nodes activities:

$$\Theta(x_i * W) = \frac{1 - e^{-x_i * W}}{1 + e^{-x_i * W}} \tag{2}$$

where  $\theta$  represents the transfer function,  $x$  represents the input vector, and  $W$  represents the weigh vector. For computation of output activities, the linear transfer function was employed:

$$\Theta(x_i * W) = x_i * W \tag{3}$$

The Levenberg-Marquardt batch learning procedures using momentum were applied, and the number of hidden layer nodes and the number of iteration steps used for training procedures was optimized, leading to the best possible description of retention behavior.

The program for multiple linear regression and artificial neural networks retention models was created by the authors on the MATLAB environment (MATLAB 6.0, MathWorks, Sherborn, MA, USA). All the calculations were performed on an IBM compatible personal computer equipped with a 266 MHz Pentium IV processor and 512 Mb RAM.

## RESULTS AND DISCUSSION

The results of application of multiple linear regression for calculation of coefficients of the proposed equation are shown in Table 2. The interpretation of the resulting equation is in terms of the relative contributions of independent variables (eluent flow rate and concentration of  $\text{OH}^-$  in eluent) to the response (retention time of particular anion). It can be seen (Table 2) that the concentration of  $\text{OH}^-$  in eluent ( $a_4$ ) has a particularly large influence on retention of sulfate and phosphate. This is due to the fact that the ionic form of sulfate and phosphate in solution depends on pH value. Retentions of fluoride, chloride, nitrite, and nitrate also are the most influenced by concentration of KOH in eluent ( $a_4$ ), while bromide is most influenced by eluent flow rate ( $a_3$ ). This shows that bromide has a nearly constant affinity towards the stationary phase. The second largest influence on retention is eluent flow rate ( $a_3$ ). The large values of  $a_4$  and  $a_3$  coefficients justify the inverse proportional relation between retention time and concentration of  $\text{OH}^-$  in eluent and retention time and eluent flow rate. It also can be seen that the term ( $x_1 \cdot x_2$ ), which shows the influence of eluent flow rate on concentration of  $\text{OH}^-$  in eluent, cannot be neglected since  $a_5$  has considerable value.

From Table 2 it can be seen that correlation coefficients are greater than 0.988, which is a very satisfactory value. But, those coefficients of correlation represent deviations of 16 experimental data points used for multiple linear regression retention modeling calculations from the calculated retention model itself. They do not represent the deviation of the retention model from the actual ion chromatographic retention behavior. For that reason the validation of the proposed retention model with the experimental data set that was not used for modeling procedure was applied.

The artificial neural network model was optimized in terms of obtaining a precise and accurate retention model. From Fig. 3, it can be seen that minimal relative error of the proposed neural network retention model is obtained by using three hidden layer nodes and 300 iteration steps. It is also shown that the number of iteration steps has a low influence on relative error, particularly in comparison with influences that have a number of hidden layer nodes on relative error. However, one of the important factor that has to be considered is reducing computation time. If the number of iteration steps is higher, the computation time is longer. That fact only confirms the previous conclusion that the optimal number of iteration steps is 300. From Fig. 4 it can be seen

**Table 2.** Retention model equation coefficients calculated by using multiple linear regression. 16 Experimental data points were used for calculations

	Fluoride	Chloride	Nitrite	Sulfate	Bromide	Nitrate	Phosphate
Coefficients of the equation							
$a_0$	0.4980	0.6746	0.8319	0.5781	1.1562	1.3275	0.1925
$a_1$	-0.0832	-0.0999	-0.0841	-0.1981	-0.0084	-0.0796	-0.2546
$a_2$	-0.0014	-0.0023	-0.0041	-0.004	-0.0061	-0.0059	-0.0011
$a_3$	0.2458	0.2963	0.3343	0.3081	0.4078	0.2987	0.3964
$a_4$	3.0221	4.8528	3.0933	18.3406	-0.0019	0.9958	38.3015
$a_5$	0.0010	0.0006	0.0003	0.0024	-0.0018	-0.0014	0.0038
Correlation coefficients	0.9988	0.9974	0.9953	0.9973	0.9880	0.9928	0.9927

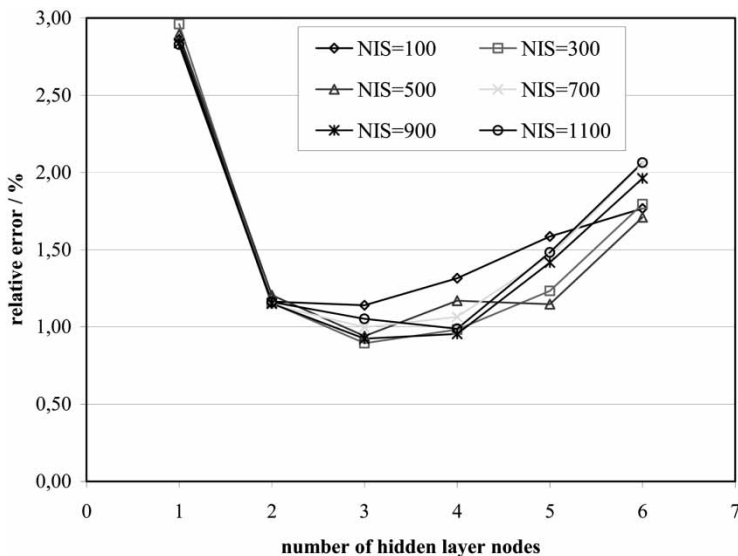

**Figure 3.** Optimization of artificial neural network retention model. Relative error against number of hidden layer nodes obtained by using different number of iteration steps (NIS).

that number of experimental data points used for the training set has significant influence on selection of optimal parameters (number of hidden layer nodes and number of iteration steps) for the artificial neural network retention model. Reducing the number of experimental data points used for the training set is crucial for development of a retention model without losing time on unnecessary experimentation. It is also important that the small number of experimental points in the training set do not decrease the predictive ability of the retention model. From Fig. 4 it can be seen that the relative error has higher values if is used with a small number of experimental data points for training set (8, 12, or 16 experimental data points). When using more experimental data points for the training set (16, 19, 22, 26, or 32 experimental data points) relative error has a smaller, but nearly the same, value. It can be concluded that the optimal number of experimental data points used for training set is 16. The optimal artificial neural network retention model was obtained by using 16 experimental data points in a training set identical to the experimental data set used for multiple linear regression retention modeling. The obtained artificial neural network retention model was validated with an external set of data identical to multiple linear regression validation set.

The amount of knowledge and time spent to develop the multiple linear regression retention model is significantly lower than that needed to

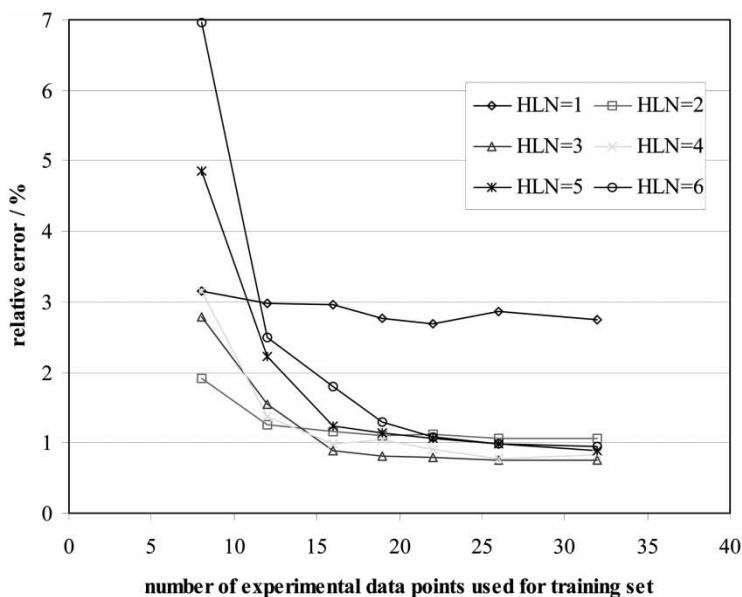

**Figure 4.** Optimization of artificial neural network retention model. Relative error against number of experimental data points used for training set obtained by using different numbers of hidden layer nodes (HLN).

develop an artificial neural network retention model. Multiple linear regression calculations need knowledge of sophisticated linear algebra, which includes the calculation of sub- and inversion matrices. Artificial neural network calculations, along with knowledge of the calculation of sub- and inversion matrices, require knowledge of nonlinear optimization, which includes the calculations of Hessian and Jacobian matrices. The amount of knowledge needed to develop one artificial neural network retention model which describes retention times of all seven inorganic anions, is nearly similar to the amount of knowledge needed to develop separate ANN retention models for each anion. However, time used for modeling is significantly lower if only one artificial neural network retention model has to be developed. It is due to the fact that in this particular case of retention modeling, a neural network with two inputs and seven outputs is not much more complex than a neural network with two inputs and one output.

The prediction power of the multiple linear regression retention model can be comparable to the artificial neural network retention model if the prediction power calculations are based on an external set of experimental data. The prediction powers of developed models were tested and results are shown on Figs. 5 and 6. The figures show that relationships between simulated retention times ( $y$ ) against measured retention times ( $x$ ) were investigated.

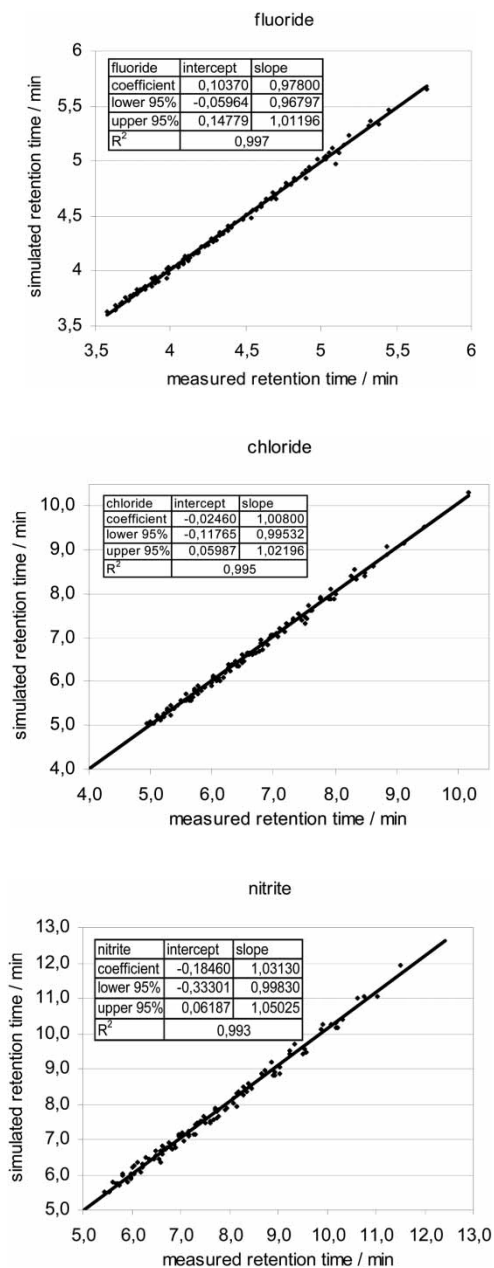

**Figure 5.** Validation results of multiple linear regression retention model obtained by using external experimental data set. The 112 experimental data points were used for calculations.

(continued)

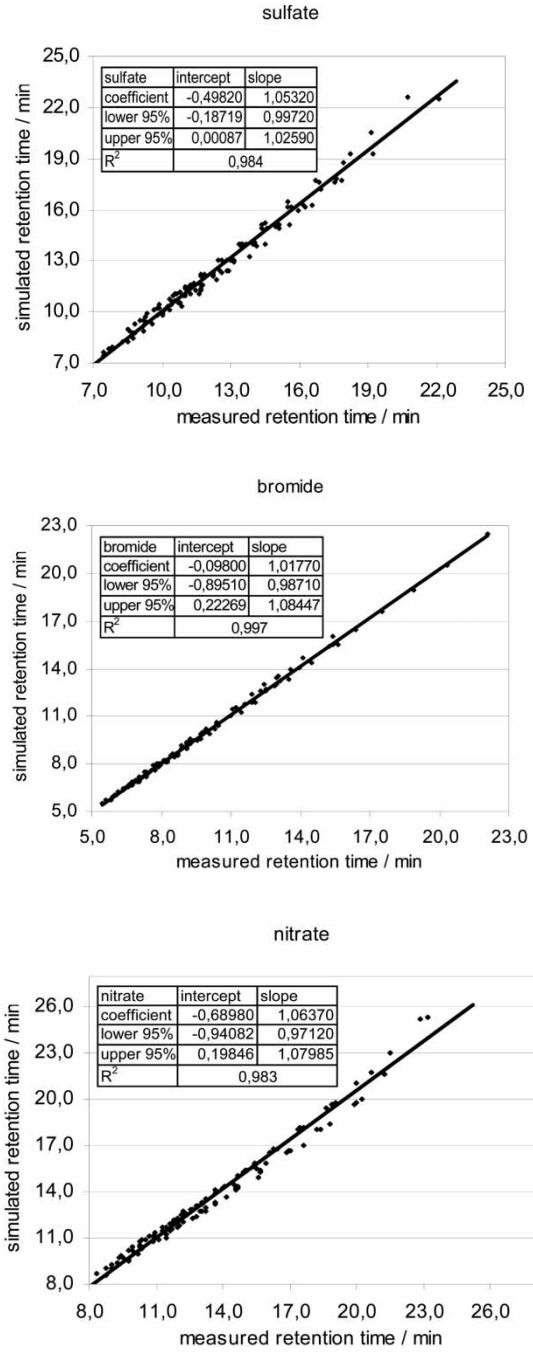
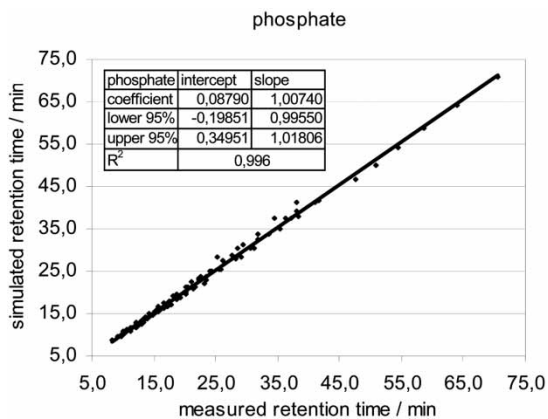

Figure 5. Continued.



*Figure 5.* Continued.

If there are no modeling errors and no measurement random errors were made, and if there were no bias, this would yield the relationship  $y = x$ . Because at least random errors were made, the coefficients of linear relationship were different (intercept was different from zero and/or slope was different from one). There are four possibilities, namely:

- if intercept is equal to zero and slope is equal to one, there is no systematic error.
- if intercept is equal to zero and slope is different from one, there is a proportional systematic error.
- if intercept is different from zero and slope is equal to one, there is absolute systematic error.
- if there is no linearity, it is necessary to carry out the modeling over a shorter ion chromatographic parameter range (if this is still compatible with original aim).

It can be seen from Figs. 5 and 6 that lower and upper 95% confidence interval limit boundaries for intercept include value zero. This proves that intercept is not significantly different from zero with respect to a confidence interval of 95%. Furthermore, lower and upper 95% confidence interval limit boundaries for slope include value one, which proves that slope is not significantly different from one with a confidence interval of 95%. On the basis of previous discussion it can be stated that there is no systematic error present in optimized artificial neural network retention models for all anions.

From Fig. 7 it can be seen that the multiple linear regression retention model provides the best results for modeling fluoride and chloride retention



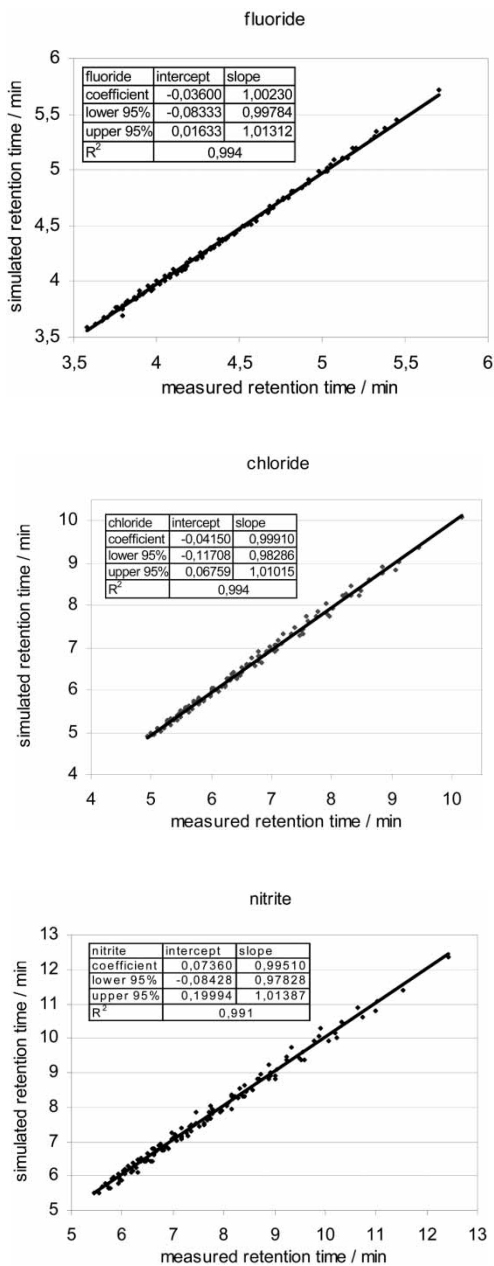

**Figure 6.** Validation results of artificial neural network retention model obtained by using an external experimental data set. The 112 experimental data points were used for calculations.

(continued)

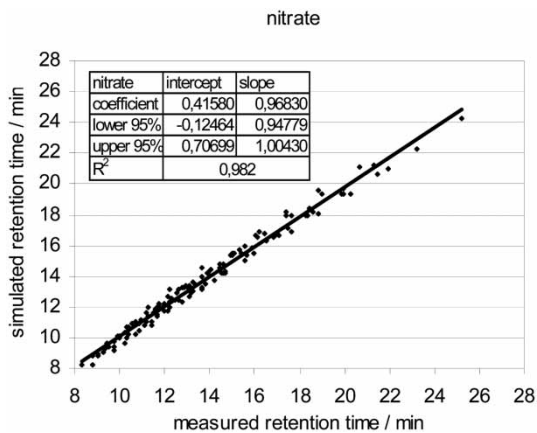
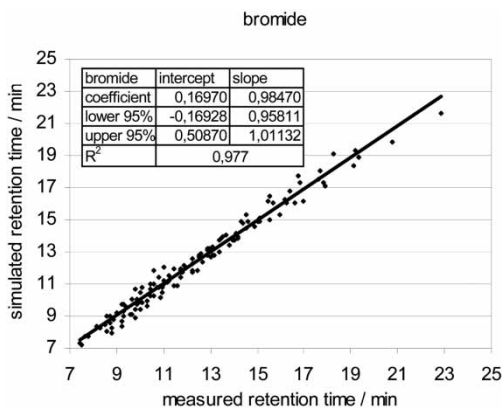
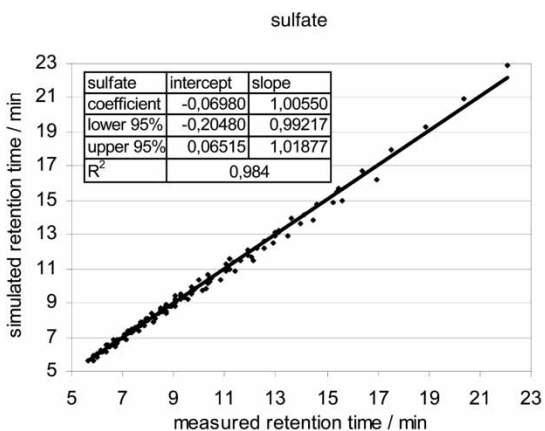

*Figure 6.* Continued.

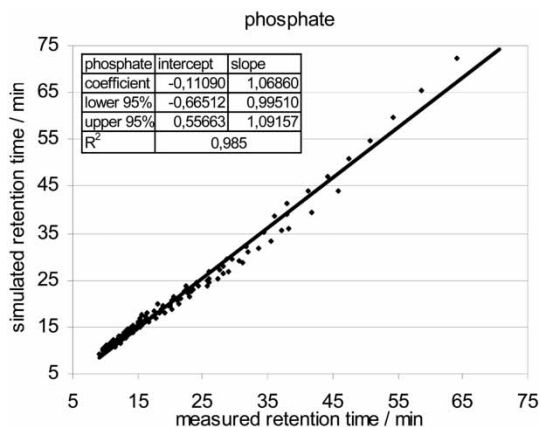

Figure 6. Continued.

( $R^2 = 0.994$ ) followed by nitrite ( $R^2 = 0.994$ ). Prediction power for retention of phosphate ( $R^2 = 0.985$ ), sulfate ( $R^2 = 0.984$ ), and nitrate ( $R^2 = 0.982$ ) is also very satisfactory and the lower prediction ability of the multiple linear regression retention model is obtained for bromide ( $R^2 = 0.977$ ). Figure 7 shows that nearly the same predictive power of an artificial neural network retention model is obtained for fluoride and bromide ( $R^2 = 0.997$ ), phosphate ( $R^2 = 0.996$ ), chloride ( $R^2 = 0.995$ ), and nitrite ( $R^2 = 0.993$ ). Prediction power for sulfate ( $R^2 = 0.984$ ) and nitrate ( $R^2 = 0.983$ ) is only slightly lower.

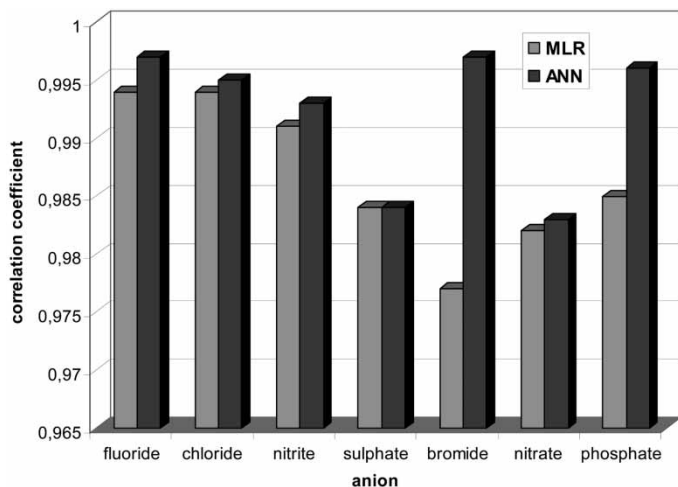

Figure 7. Comparison of retention models developed by using multiple linear regression and by using artificial neural networks.

By summarizing the results from Figs. 5, 6, and 7, it can be stated that the artificial neural network retention model has better ability to predict retention times of each and every modeled anion. However, both of the models show very good predictive ability. It can be concluded that for ion chromatographic separation with isocratic elution it is possible to apply the multiple linear regression retention model without making significant errors in global optimization of separation (retention modeling) procedure.

## CONCLUSIONS

This study describes development of multiple linear regression and artificial neural network retention models that can be used for resolving separation problems in ion chromatography with isocratic elution. To underline the advantages of the proposed methodology, the multiple linear regression retention model was compared to the artificial neural networks retention model. It is shown that the artificial neural network has better prediction ability, but correlation coefficients for multiple linear regression are still very satisfactory. Due to their complexity, artificial neural networks must be regarded as a more complicated technique compared to multiple linear regression. More than basic knowledge about artificial neural networks and computer programming is needed to create artificial neural network retention modeling and further optimization of separation in ion chromatography used at least, a time consuming process. Multiple linear regression retention modeling is less time consuming, simple to understand, and does not require theory knowledge about artificial neural networks and more sophisticated computer programming methodology. This information indicates multiple linear regression retention modeling as a preferred choice, convenient to use when simplicity and time spend for modeling is a more important factor than is slightly better predictive ability in global optimization of separation in ion chromatographic analysis with isocratic elution.

This study also shows that separation in ion chromatography with isocratic elution strongly depends on applied ion chromatographic conditions (eluent flow rate, concentration of  $\text{OH}^-$  in eluent). The developed retention models allow manipulating with the appearance of the particular peak on the chromatogram and allow improvement of separation between particular anions. By using those retention models, it is possible both to improve performance characteristics of the applied method and to speed up new method development by reducing unnecessary experimentation.

## REFERENCES

1. Weiss, J. (1995) *Ion Chromatography*, 2nd Ed.; VCH: Weinheim.
2. Fritz, J.S. and Gjerde, D.T. (2000) *Ion Chromatography*, 3rd Ed.; Wiley-VCH: New York.

3. Thienpont, L.M., Van Nuwenborg, J.E., and Stöckl, D. (1997) Ion chromatography as reference method for serum cations. *J. Chromatogr. A*, 789: 557–568.
4. Buldini, P.L., Cavalli, S., and Trifirò, A. (1997) State-of-the-art ion chromatographic determination of inorganic ions in food. *J. Chromatogr. A*, 789: 529–548.
5. Haddad, P.R., Doble, P., and Macka, M. (1999) Developments in sample preparation and separation techniques for the determination of inorganic ions by ion chromatography and capillary electrophoresis. *J. Chromatogr. A*, 856: 145–177.
6. Lopez-Ruiz, B. (2000) Advances in the determination of inorganic anions by ion chromatography. *J. Chromatogr. A*, 881: 607–627.
7. Sarzanini, C. (2002) Recent developments in ion chromatography. *J. Chromatogr. A*, 956: 3–13.
8. Shaw, M.J. and Haddad, P.R. (2004) The determination of trace metal pollutants in environmental matrices using ion chromatography. *Environment International*, 30 (3): 403–431.
9. Madden, J.E. and Haddad, P.R. (1998) Critical comparison of retention models for optimisation of the separation of anions in ion chromatography: I. Non-suppressed anion chromatography using phthalate eluents and three different stationary phases. *J. Chromatogr. A*, 829: 65–80.
10. Madden, J.E. and Haddad, P.R. (1999) Critical comparison of retention models for the optimisation of the separation of anions in ion chromatography: II. Suppressed anion chromatography using carbonate eluents. *J. Chromatogr. A*, 850: 29–41.
11. Gjerde, D.T., Schmuckler, G., and Fritz, J.S. (1980) Anion chromatography with low-conductivity eluents. II. *J. Chromatogr. A*, 187: 35–45.
12. Haddad, P.R. and Cowie, C.E. (1984) Computer-assisted optimization of eluent concentration and pH in ion chromatography. *J. Chromatogr.*, 303: 321–330.
13. Jenke, D.R. and Pagenkopf, G.K. (1984) Optimization of anion separation by non-suppressed ion chromatography. *Anal. Chem.*, 56: 85–88.
14. Jenke, D.R. and Pagenkopf, G.K. (1984) Models for prediction of retention in non-suppressed ion chromatography. *Anal. Chem.*, 56: 88–91.
15. Jenke, D.R. (1984) Modeling of analyte behavior in indirect photometric chromatography. *Anal. Chem.*, 56: 2674–2681.
16. Maruo, M., Hirayama, N., and Kuwamoto, T. (1989) Ion chromatographic elution behaviour and prediction of the retention of inorganic monovalent anions using a phosphate eluent. *J. Chromatogr.*, 481: 315–322.
17. Jenke, D.R. (1994) Prediction of retention characteristics of multiprotic anions in ion chromatography. *Anal. Chem.*, 66: 4466–4470.
18. Hajos, P., Horvath, O., and Denke, V. (1995) Prediction of retention for halide anions and oxoanions in suppressed ion chromatography using multiple species eluent. *Anal. Chem.*, 67: 434–441.
19. Novič, Ma., Zupan, J., and Novič, Mi. (2001) Computer simulation of ion chromatography separation: an algorithm enabling continuous monitoring of anion distribution on an ion-exchange chromatography column. *J. Chromatogr. A*, 922: 1–11.
20. Sacchero, G., Buzzoniti, M.C., Sarzanini, C., Mentasti, E., Metting, H.J., and Coenegracht, P.M.J. (1998) Comparison of prediction power between theoretical and neural-network models in ion-interaction chromatography. *J. Chromatogr. A*, 799: 35–45.
21. Madden, J.E., Avdalovic, N., Jackson, P.E., and Haddad, P.R. (1999) Critical comparison of retention models for optimisation of the separation of anions in ion

- chromatography: III. Anion chromatography using hydroxide eluents on a Dionex AS11 stationary phase. *J. Chromatogr A*, 837: 65–74.
22. Havel, J., Madden, J.E., and Haddad, P.R. (1999) Prediction of retention times for anions in ion chromatography using artificial neural networks. *Chromatographia*, 49: 481–488.
  23. Madden, J.E., Avdalovic, N., Haddad, P.R., and Havel, J. (2001) Prediction of retention times for anions in linear gradient elution ion chromatography with hydroxide eluents using artificial neural networks. *J. Chromatogr. A*, 910: 173–179.
  24. Jimenez, O. and Marina, M.L. (1997) Retention modeling in micellar liquid chromatography. *J. Chromatogr. A*, 780: 149–163.
  25. Garcia-Alvarez-Coque, M.C., Torres-Lapasio, J.R., and Baeza-Baeza, J.J. (1997) Modelling of retention behaviour of solutes in micellar liquid chromatography. *J. Chromatogr. A*, 780: 129–148.
  26. Mulholland, M., Hibbert, D.B., Haddad, P.R., and Parslov, P.A. (1995) Comparison of classification in artificial intelligence, induction versus a self-organising neural networks. *Chemom. Intell. Lab. Syst.*, 30: 117–128.