

Use of Artificial Neural Networks for Retention Modelling in ion Chromatography

Srečnik, Goran; Debeljak, Željko; Cerjan-Stefanović, Štefica; Bolanča, Tomislav; Novič, Milko; Lazarić, Katica; Gumhalter-Lulić, Željka

Source / Izvornik: **Croatica Chemica Acta, 2002, 75, 713 - 725**

Journal article, Published version

Rad u časopisu, Objavljena verzija rada (izdavačev PDF)

Permanent link / Trajna poveznica: <https://um.nsk.hr/um:nbn:hr:239:241939>

Rights / Prava: [Attribution 4.0 International](#)/[Imenovanje 4.0 međunarodna](#)

Download date / Datum preuzimanja: **2024-12-26**



Repository / Repozitorij:

[Repository UHC Osijek - Repository University Hospital Centre Osijek](#)

Use of Artificial Neural Networks for Retention Modelling in Ion Chromatography

Goran Srečnik,^a Željko Debeljak,^a Štefica Cerjan-Stefanović,^b Tomislav Bolanča,^{b,*} Milko Novič,^c Katica Lazarić,^a and Željka Gumhalter-Lulić^a

^aAnalytical Development Department, Pliva, Pharmaceutical Industry,
Prilaz baruna Filipovića 25, 10000 Zagreb, Croatia

^bLaboratory of Analytical Chemistry, Faculty of Chemical Engineering
and Technology, Marulićev trg 20, 10000 Zagreb, Croatia

^cNational Institute of Chemistry, Hajdrihova 19, 1001 Ljubljana, Slovenia

Received July 17, 2001; revised April 2, 2002; accepted April 18, 2002

The aim of this work was to develop an empirical model for retention of inorganic anions (fluoride, chloride, nitrite, sulphate, bromide, nitrate, and phosphate) in suppressed ion chromatography with hydroxide selective stationary phases using artificial neural networks. Three-layer feed-forward neural network trained with a Levenberg-Marquardt batch error back propagation algorithm has been used to model retention mechanisms of inorganic anions with respect to the mobile phase parameters. The number of hidden layer nodes of the neural network and the number of iteration steps were optimized in order to obtain the best possible retention model. This study shows that an optimized artificial neural network is a very accurate and fast retention modelling tool to model various inherent linear and non-linear relationships of retention behaviour. This has been proven by developing the neural network retention model with average relative errors of 0.88% obtained using only 300 iteration steps.

Key words: ion chromatography, retention modelling, artificial neural networks.

* Author to whom correspondence should be addressed. (E-mail: tbolanca@pierre.fkit.hr)

INTRODUCTION

Anion separation by suppressed and non-suppressed ion chromatography has become a routine analytical procedure in recent years.¹⁻⁴ This technique offers a reliable methodology for simultaneous determination of ions and has been found to be useful in many applications, *e.g.*, environmental, industrial and clinical analysis. An interesting aspect of anion chromatography is the selectivity of separation. An understanding of the rules that influence selectivity is essential for optimizing the conditions for difficult separations. The most important factors influencing selectivity are the eluent anion, its charge, eluent concentration and pH, eluent flow rate,⁵ as well as the sorbent matrix, functional group and its content. The influence of the character of the functional group,⁶⁻⁸ space length⁹ and character of the support¹⁰ was studied earlier. Retention models for ion chromatography were evaluated and only partial agreement was found between theoretical models and experimental data.^{11,12} There is still much to be investigated, the problem of the selectivity of mono- and divalent anions having been neglected so far.

Development of computer-assisted retention modelling routines in ion chromatography can be approached in a number of ways. Two types of retention models can be identified – theoretical and empirical. A theoretical model is derived from fundamental equations and invariably requires knowledge of a range of parameters relating to the analyte, stationary phase, and eluent, before the calculation of the retention time of the analyte is possible.¹³⁻¹⁷ On the other hand, empirical models concentrate on predicting the manner in which retention changes, when some ion chromatographic parameter is varied between two or more known values, rather than on the underlying theoretical explanation of these changes.

The use of the machine learning methods for empirical retention modelling represents the fundamental research issue. The ability of the computer to learn independently is a recognised manifestation of intelligence and offers the potential to build an intelligent system more efficiently. There are many different approaches to developing a method of machine learning. Techniques that are currently popular include artificial neural networks (ANN), genetic algorithms (GA), and induction¹⁸ ANN and operate in a manner that mimics our current understanding of the architecture of the brain, which is postulated to consist of 10^9 to 10^{12} of linked neurons. These algorithms attempt to model the relationship between attributes by a similar network, which finally becomes the rather abstract knowledge representation of the expert system. The main drawback of these systems is that the knowledge representation, a network of neurons connected by various weighting factors, is hard to decode and alter. Hence, the future maintenance is complex and the results may not be obvious.^{19,20}

In this work, the ANN was used for retention modelling of the anion separation in ion chromatography. Influence of the eluent flow rate and eluent anion concentration (OH^-) on the separation of seven inorganic anions (fluoride, chloride, nitrite, bromide, nitrate, sulphate and phosphate) were investigated. Main advantages of the developed ANN retention model over other models is description of the whole ion chromatographic separation system at the same time and use of a huge set of testing data, consisting of 112 experimental points, which guarantee the reliability of the proposed model. A unique technique of experimental data selection for the training set was used, enabling improvement of the ANN prediction power. The aim of this work is to characterise ANN in terms of the number of nodes in hidden layers and the number of iteration steps leading to a more accurate description of the retention model.

Methodology

Neural network ideas were developed in the 1950's but went into decline in the 1960's when it was proven that the linear architecture used at that time was unable to solve nonlinear problems. Only with the advent of new network architectures and teaching algorithms in the mid-1970's and early 1980's did their true application potential become evident. As recent detailed books and articles on the ANN theory and its applications to chemistry are available,^{19,22} only a brief description of neural network concepts will be given here.

A rather unique concept of neural networks are the multi-layered feed-forward neural networks. A multi-layered feed-forward neural network consists of three or more layers of nodes: one input layer, one output layer and one or more hidden (intermediate) layers. A node in one layer is connected to all nodes in the next layer (feed-forward architecture). A node receives and/or sends signals from/to other nodes or the outside world *via* the network connections. Each signal is weighted by a weight factor associated with a connection. The node input is determined by the incoming (weighted) signals, the node output is a function of the input. Usually, a linear function is used for the input layer (input nodes are simple flow-through nodes) while the sigmoidal function is often used for the hidden nodes to enable modelling of non-linear relations. The transfer function of the output nodes depends on the required output of the networks. If this output is qualitative, a sigmoid transfer function is usually used. If the output is quantitative, a linear function may be used.

Adequate functioning of a neural network is highly dependent on the way the signals are propagated through the network. This signal propagation is determined by the weights of the connections. In general, the proper

weight setting is not known beforehand and therefore the weights are initially given a random value. The process of updating the weights to correct values is called training or learning. A correct weight set is usually achieved by means of supervised learning. The back-propagation learning rule is often used. According to this learning rule, in, for example, a three layer neural network, first the weights from the hidden layer to the output layer are adopted, and then the weights from the input layer to the hidden layer. Various learning rules can be used for weight adaptations, for example: the Delta learning rule, Levenberg-Marquardt learning rule, *etc.*²³⁻²⁶

During and after the training, the network performance has to be tested. This is done with a test set consisting of other examples comparable to the set of examples that was used for the network training. In the testing phase, the input quantities are fed to the network, and the desired output quantities are compared with the output quantities produced by the neural network. The (dis)agreement of the two sets of output quantities gives an indication if the performance meets the requirements specified in advance and if the network is ready for real analysis purposes. In Figure 1, a possible neural network structure and a schematic diagram of neural network learning are shown.

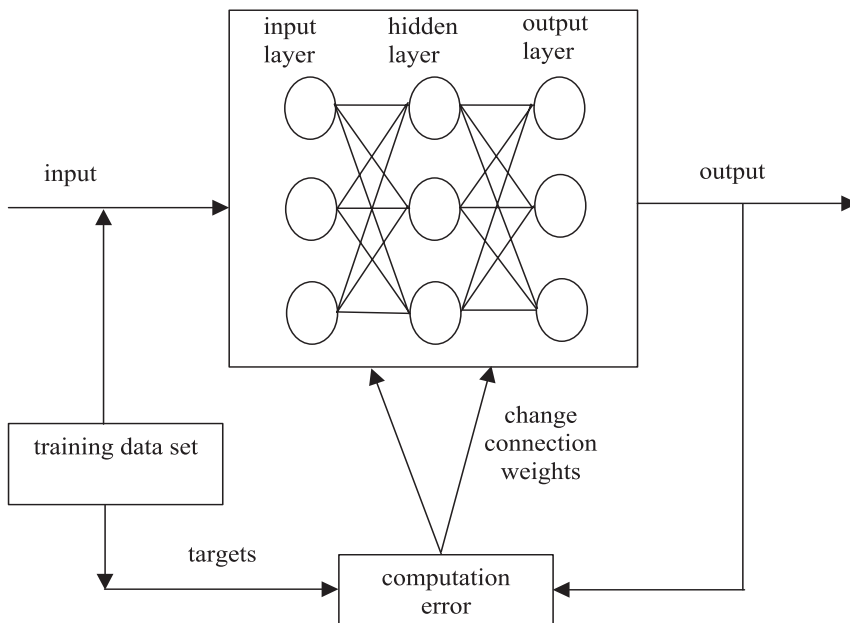

Figure 1. A possible neural network structure and schematic diagram of the neural network learning process.

EXPERIMENTAL

Reagents

Stock solutions of fluoride (1.0000 g/L), chloride (1.0000 g/L), nitrite (1.0000 g/L), sulphate (1.0000 g/L), bromide (1.0000 g/L), nitrate (1.0000 g/L) and phosphate (1.0000 g/L) were prepared from the air-dried (at 105 °C) salts of individual anions of *p.a.* grade (Merck, Darmstadt, Germany). The appropriate amount of salt was added into a volumetric flask (100 mL) and dissolved with Milli-Q water. Working standard solutions of fluoride (2.00 mg/L), chloride (5.00 mg/L), nitrite (10.00 mg/L), sulphate (10.00 mg/L), bromide (20.00 mg/L), nitrate (20.00 mg/L), and phosphate (30.00 mg/L) were prepared by measuring the appropriate volume of stock solution of a particular anion into a 100 ml volumetric flask, which was later filled to the mark with Milli-Q water. Working eluent solutions were prepared on-line by appropriate dilution of KOH with Milli-Q water. 18 M Ω cm⁻¹ water (Millipore, Bedford, MA, USA) was used for dilution in all cases.

Apparatus

The Dionex DX500 chromatography system (Sunnyvale, CA, USA) equipped with a quaternary gradient pump (GP50), eluent generator module (EG40), chromatography module (LC25) and detector module (ED40) was used in all experiments. Separation and suppressor columns used were the Dionex IonPac AG15 (4 × 50 mm) guard column, IonPac AS15 (4 × 250 mm) separation column and ASRS-ULTRA-4 mm suppressor column, working in the recycle mode. The sample-loop volume was 50 μ l.

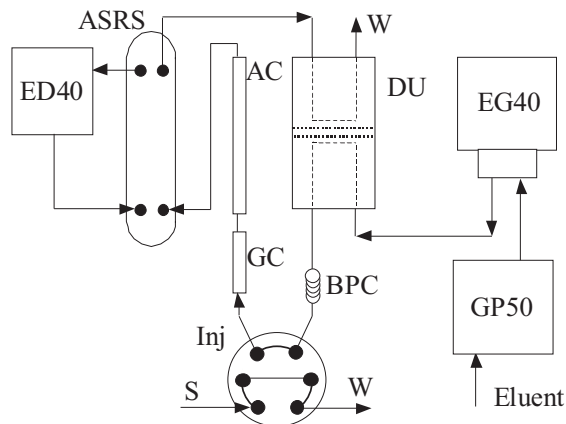

Figure 2. Scheme of the DX500 ion chromatography system with a built-in electro-dalytic KOH generator (EG40). – GP50, quaternary gradient pump; EG40, eluent generator; DU, degas module; Inj, injector; GC, guard column (AG4A-SC); AC, analytical column (AS4A-SC), ASRS, suppressor column (ASRS-ULTRA, recycle mode); BPC, back-pressure coil; ED40, electrochemical detector (conductivity mode); S, sample; eluent, OH⁻; W, waste.

The eluent flow rates were 1.00 to 1.95 mL/min and OH⁻ concentration in eluent was 25.00 to 60.00 mmol/L. The whole system was computer controlled by means of PeakNet 5.1 software.

The data for further evaluation were obtained by exporting the appropriate chromatograms into ASCII files. ASCII data files were further evaluated using the Microcal Origin (Microcal Software, USA) software package. The scheme of the applied chromatography set-up is schematically presented in Figure 2.

Experimental Design

The experimental design was planned in such a way as to describe the chromatographic behaviour in a multi-dimensional space: retention time *versus* eluent flow rate and OH⁻ concentration in eluent. The eluent flow rate was varied in a range from 1.00 to 1.95 mL/min and the OH⁻ concentration in eluent was varied from 25.00 to 60.00 mmol/L. The 128 experimental data points were obtained. The experimental data used in the modelling procedure are presented in Table I (see Supplementary material). The experimental data points were logarithmically (\log_{10}) transformed before modelling, because of the heteroscedastic nature of the retention times variance. This provided the homogeneous variance in the network output (retention times of fluoride, chloride, nitrite, sulphate, bromide, nitrate, and phosphate). In Table I, all retention time data (columns 3 to 5) are logarithmically transformed (\log_{10}).

The independent training set (16 experimental data points) and the test set (112 experimental data points) were selected to cover the whole design space. For that purpose, the design space (128 experimental data points) was divided into 16 subspaces from which one experimental data point was chosen for the training set from each subspace, using the random function. The remaining 112 experimental data points were used for the testing set. All calculations relating to the training and testing procedures were repeated 10 times, including the selection of experimental data points (using the random function) for the training (16 experimental data points) and testing (112 experimental data points) sets.

Neural Networks

The neural network used in this paper was a feed-forward backpropagation neural network. The input layer consisted of two nodes, representing the eluent flow rate and the OH⁻ concentration of the eluent. The output layer consisted of seven nodes representing the retention times of seven inorganic anions (fluoride, chloride, nitrite, sulphate, bromide, nitrate and phosphate). The network had one hidden layer and the number of hidden layer neurons was varied from 1 to 6 in order to provide the best possible solution of the retention modelling problem. Two different transfer functions were used. The hyperbolic tangent sigmoid transfer function was used for computation of the hidden layer nodes activities:

$$\Theta(x_i * W) = \frac{1 - e^{-x_i * W}}{1 + e^{-x_i * W}} \quad (1)$$

where Θ is the transfer function, \mathbf{x} is the input vector, and \mathbf{W} represents the weight vector. For computation of output activities, the linear transfer function was employed:

$$\Theta(\mathbf{x}_i * \mathbf{W}) = \mathbf{x}_i * \mathbf{W} \quad (2)$$

The momentum using Levenberg-Marquardt batch learning procedures were applied, and the number of hidden layer nodes and the number of iteration steps used for training procedures were optimized, leading to the best possible description of the retention behaviour.

The program for the neural network was made by the authors on the MATLAB environment (MATLAB 6.0, MathWorks, Sherborn, MA, USA). All the calculations were performed on an IBM compatible personal computer equipped with an 800 MHz Pentium III processor, and 256 Mb RAM.

Optimization of the Neural Network

The optimal numbers of hidden nodes and iteration steps should be chosen in order to obtain a good performance model. Therefore, the number of hidden nodes was varied from 1 to 6 and the number of iteration steps was varied from 100 to 1100. The optimal numbers of hidden nodes and iteration steps were determined by validating the ANN performance with a separate test set of experimental data during a training.

The testing procedures involved the cross-validation procedure and application of Dixon's outlier filter.²⁰ Dixon's outlier test was used for exclusion of outliers during optimization of network parameters, followed by the retraining procedure using different neural network parameters (initial weight vector, momentum factor) for the purpose of obtaining a better generalization of the retention mechanism.

To test the performance of the developed artificial neural network retention model, an independent test set (112 experimental data points) was used to calculate the relative error, average of relative errors and MPRESS (mean predicted residual sum of squares). The following equations were used in calculations:

$$\text{relative error} = \left(\frac{1}{N} \sum_i^N \frac{|y_i - y_{ip}|}{y_{ip}} \right) \times 100 \quad (3)$$

$$\text{average of relative errors} = \frac{1}{M} \sum_i^M (\text{relative error})_i \quad (4)$$

$$\text{MPRESS} = \frac{1}{N} \sum_i^N (y_i - y_{ip})^2 \quad (5)$$

where y_i represents the mean value of the neural network output (retention times of particular ions), y_{ip} is the predicted value of the neural network output, N represents the number of cases used for calculations of statistical parameters ($N = 112$ for each calculation) and M is the number of neural

network outputs (fluoride, chloride, nitrite, sulphate, bromide, nitrate, and phosphate). All relative errors, averages of relative errors and MPRESS were calculated as an average of non-logarithmically transformed data obtained after 10 testing runs (each run with 112 experimental data points). The results of the neural network optimization procedures are shown in Figures 3 and 4 and in Table II.

TABLE II

Performance characteristics of the developed artificial neural network retention model (relative errors, average of relative errors, MPRESS) for the best results of the optimization process (number of iteration steps, number of hidden layer nodes)

iteration steps		100	300	500	700	900	1100
hidden layer node		3	3	3	3	3	4
relative error / %	F ⁻	1.15	0.58	0.63	0.70	0.66	0.52
	Cl ⁻	1.23	0.87	0.92	1.01	0.92	0.88
	NO ₂ ⁻	0.93	0.85	0.89	0.99	0.86	0.97
	SO ₄ ²⁻	0.89	0.77	0.82	0.83	0.78	0.85
	Br ⁻	1.38	1.14	1.17	1.29	1.18	1.39
	NO ₃ ⁻	1.18	1.00	1.10	1.10	1.05	1.22
	PO ₄ ³⁻	1.21	1.06	1.06	1.07	1.01	1.08
average of relative errors / %		1.14	0.89	0.94	1.00	1.92	0.94
MPRESS / 10 ⁻⁴		2.51	1.66	1.94	2.12	1.71	2.08

^a All relative errors, averages of relative errors and MPRESS were calculated as an average of non-logarithmically transformed data obtained after 10 testing runs (each run with 112 experimental data points).

RESULTS AND DISCUSSION

The results of the artificial neural network optimization procedures, using 128 experimental data points for the retention modelling procedure (Table I), can be discussed as follows.

Figure 3 shows that in the case of 100 iteration steps, the optimal number of hidden nodes is three rather than two. The average of relative errors of ANN with three hidden nodes is 1.14% and with two hidden nodes 1.16%, which is a very close margin to decide the actual number of hidden nodes using 100 iteration steps. However, if three hidden nodes are used, the relative error ranges between a minimum of 3.22% for nitrite and a maximum of 5.49% for phosphate while MPRESS is 2.51×10^{-4} (Table II).

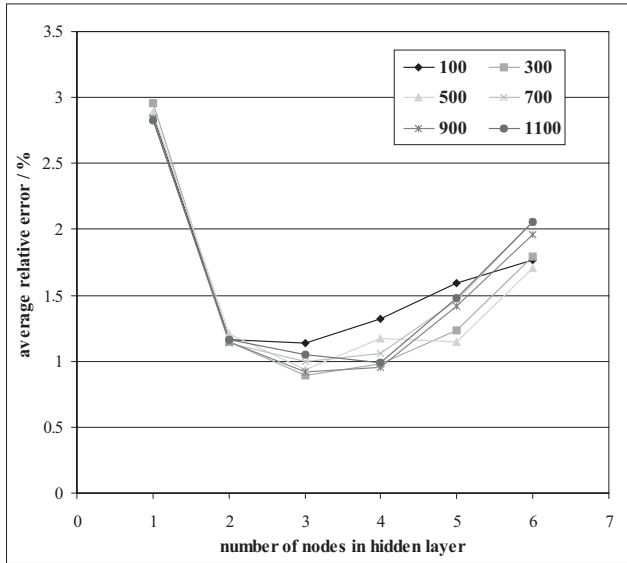

Figure 3. Optimization of the number of nodes in the hidden layer using 100, 200, 300, 500, 700, 900 and 1100 iteration steps. Average of relative errors against the number of nodes in the hidden layer.

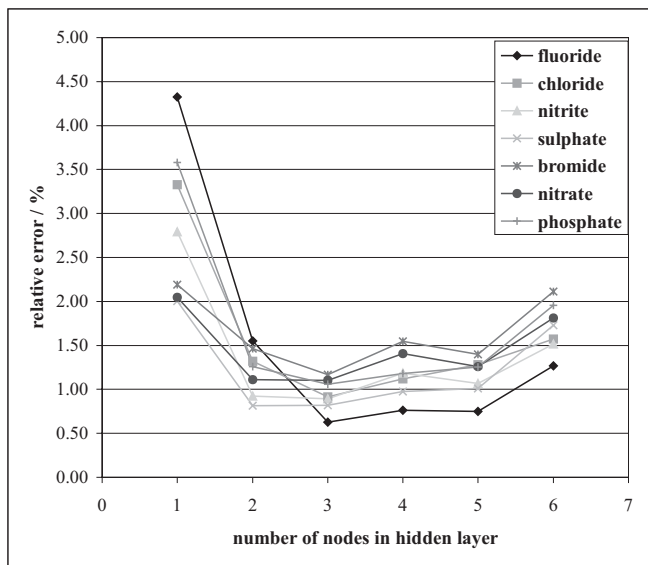

Figure 4. Relative errors of fluoride, chloride, nitrite, sulphate, bromide, nitrate and phosphate against the number of nodes in the hidden layer for the optimal number of iteration steps (300 iteration steps).

In the case of 300 iteration steps, the optimal number of hidden layer nodes is three (Figure 3). This was proven by the average of the relative errors of 0.88%, which is significantly lower than the average of relative errors in the case of 100 iteration steps. The relative error for a particular anion ranged from the exceptionally low 0.58% for fluoride to very satisfactory 1.14% for bromide (Figure 4) while MPRESS was 1.66×10^{-4} (Table II).

The shape of the curve obtained by using 500 iteration steps clearly indicates that the optimal number of hidden layer nodes is three, and the average of relative errors is 0.94% (Figure 3). In all the three previous optimization steps, the calculated optimal number of hidden layer nodes was three, while the number of iteration steps varied. This allowed to evaluate the number of iteration steps used for the learning procedure (100, 300 or 500). It can be seen that the lowest average of relative errors of 0.74% was obtained using 300 iteration steps. The relative error of a particular anion using 500 iteration steps has very close but slightly higher values than in the case of 300 iteration steps, and it ranged from 0.63% for fluoride to 1.17% for bromide while MPRESS was 1.94×10^{-4} (Table II).

When using 700 and 900 iteration steps, the optimal number of hidden layer nodes was three with an average of relative errors of 1.00% for 700 and 0.92% for 900 iteration steps (Figure 3). The both values of the average of relative errors are higher than the average of relative errors of the network with three nodes and 300 iteration steps. But despite the assumption that 700 iteration steps is a high value and that it is very likely to overtrain the network by using 700 iteration steps, the lower value of the average of relative errors in using 900 iteration steps indicates the possibility of a local minimum. Therefore, further optimization in terms of increasing the number of iteration steps is necessary. The relative error for a particular anion using 700 iteration steps ranged from 0.62% for fluoride to 1.05% for phosphate with MPRESS of 2.12×10^{-4} and by using 900 iteration steps, it ranged from 0.66% for fluoride to 1.18% for bromide with MPRESS of 1.71×10^{-4} (Table II).

In the case of 1100 iteration steps, the optimal number of hidden layer nodes was four. The average of the relative errors is 0.99%, which is higher than the average of relative errors calculated using 900 iterations steps and three hidden layer nodes (Figure 3). The relative error for a particular anion using 1100 iteration steps ranged from 0.62% for fluoride to 1.05% for phosphate while MPRESS was 2.08×10^{-4} . This indicates that the function, which the network represents in using 1100 iteration steps and 4 hidden layer nodes, is too complex and does not describe adequately the ion chromatography retention mechanism. Thus, the optimal number of hidden layer nodes is three and the optimal number of iteration steps is 300.

The results shown in Table I indicate that the selectivity of ion chromatographic methods strongly depends on the applied ion chromatographic conditions (eluent flow rate, OH^- concentration of the eluent). By adjusting the eluent flow rate and OH^- concentration of the eluent, it is possible to increase selectivity. This is a crucial factor for numerous different applications of the ion chromatography analysis, particularly for wastewater analysis and analysis of samples with very different concentrations of analyte components. The possibility of adjusting the retention times of fluoride and chloride is crucial for the determination of organic acids (acetate, formate and propionate) while the possibility of adjusting the retention times of nitrite and sulphate is crucial for butyrate and carbonate determination. By adjusting the retention times of slow-eluting anions (phosphate and nitrate) it is possible to obtain shorter ion chromatographic runs and speed up the analysis, without decreasing the selectivity of fast-eluting anions (fluoride and chloride). The developed artificial neural network retention model improves the performance characteristic of the applied method and speeds up the new method development by reducing unnecessary experimentation.

CONCLUSIONS

In this work, the ANN was used for retention modelling of anion separation in ion chromatography. The described neural network is characterized in terms of optimization of the number of nodes in the hidden layer and the number of iteration steps, leading to a more accurate description of the retention model. Problems arise when conventional cross-validation is applied to neural network models trained with the LM algorithm. Every new initialization can be regarded as a new start position for the LM search for the global minimum. Although special learning parameters (*e.g.*, momentum factor) can help avoid local minima, no guarantee of finding the global minimum can be given. The probability of finding the global minimum was enhanced by selecting various random start positions for the LM search. Consequently, there is a better chance of walking around the local minima. Obviously, the chance of finding the global minimum directly depends on the smoothness of the error hyperplane (Figure 3) and the number of local minima. Cross-validation by means of reinitializations and retraining of the networks using Dixon's filter as a criterion, enables establishment of a better neural network retention model. It can be concluded that the optimal number of nodes in the hidden layer is 3 and the optimal number of iteration steps is 300. Applying a larger number of hidden layer nodes and a larger number of iteration steps results in a considerable deterioration of per-

formance (Figure 3). In that case, the neural models become overtrained and lose their generalization ability of retention modelling.

The developed neural network is capable of retention modelling of all investigated anions (fluoride, chloride, nitrite, sulphate, bromide, nitrate and phosphate) at the same time with very superior performance. This fact was proven by the value of the average of relative errors of 0.88% and MPRESS of 1.66×10^{-4} , calculated with 112 experimental data points in the test set (Table II).

It has been shown that the selectivity of ion chromatographic methods strongly depends on the applied ion chromatographic conditions (eluent flow rate, OH⁻ concentration of the eluent). The developed retention model allows manipulation of the appearance of a particular peak on the chromatogram as well as improvement of the selectivity between particular anions. Use of this retention model makes it possible to improve the performance characteristics of the applied method and speed up the new method development by reducing unnecessary experimentation.

Supplementary material. – Table I: Experimental data set used for the retention modelling procedure. Dependence of retention times of analyzed ions (fluoride, chloride, nitrite, sulphate, bromide, nitrate, and phosphate) on ion chromatographic analysis conditions (eluent flow rate and potassium hydroxide concentration of the eluent). All retention time data (columns 3 to 5) have been logarithmically transformed (\log_{10}).

This material is available on the journal web site: <http://pubwww.srce.hr/ccaca> or on request from the authors.

Acknowledgement. – We thank Bono Lučić for his help in presenting the modeling methodology.

REFERENCES

1. H. Small, T. Stevens, and W. Bauman, *Anal. Chem.* **47** (1975) 4801–4809.
2. G. D. Frankin, *Int. Lab.* **15** (1985) 56–62.
3. P. R. Haddad and A. L. Heckenberg, *J. Chromatogr.* **300** (1984) 357–368.
4. Š. Cerjan-Stefanović, T. Bolanča, and L. Čurković, *J. Chromatogr.* **918** (2001) 325–334.
5. Š. Cerjan-Stefanović, T. Bolanča, and L. Čurković, *J. Liq. Chrom. Rel. Technol.* **23** (14) (2000) 2169–2179.
6. R. E. Barron and J. S. Fritz, *J. Chromatogr.* **284** (1984) 13–19.
7. F. Vlačil and I. Vinš, *J. Chromatogr.* **26** (1987) 133–141.
8. R. W. Slingsby and Ch. A. Pohl, *J. Chromatogr.* **485** (1988) 241–251.
9. L. Dwarth and J. S. Fritz, *J. Chromatogr. Sci.* **29** (1988) 241–253.
10. D. L. DuVal and J. S. Fritz, *J. Chromatogr.* **295** (1984) 89–98.
11. J. E. Madden and P. R. Haddad, *J. Chromatogr., Sect. A* **829** (1998) 65–80.
12. J. E. Madden and P. R. Haddad, *J. Chromatogr., Sect. A* **850** (1999) 29–41.
13. D. T. Gjerde, G. Schmuckler, and J. S. Fritz, *J. Chromatogr.* **12** (1980) 35–46.

14. T. B. Hoover, *Sep. Sci. Technol.* **17** (1982) 295–305.
15. M. Mauro, N. Hirayama, and T. Kuwamoto, *J. Chromatogr.* **481** (1989) 315–322.
16. D. R. Jenke, *Anal. Chem.* **66** (1994) 4466–4470.
17. P. Hajós, O. Horváth, and V. Denke, *Anal. Chem.* **67** (1995) 434–441.
18. M. Mulholland, D. B. Hibbert, P. R. Haddad, and P. Parslov, *Chem. Intell. Lab. Syst.* **30** (1995) 117–128.
19. J. Havel, J. E. Madden, and P. R. Haddad, *Chromatographia* **49** (1999) 481–488.
20. G. Sacchero, M. C. Bruzzoniti, C. Sarzanini, and E. Mentasti, *J. Chromatogr., Sect. A* **799** (1998) 35–45.
21. M. Smith, *Neural Networks for Statistical Modeling*, Van Nostrand Reinhold, New York, 1993.
22. J. Zupan and J. Gasteiger, *Neural Networks in Chemistry and Drug Design*, 2nd ed., Wiley-VCH, Weinheim, 1999.
23. W. H. Press, B. P. Flannery, S. A. Teukolsky, and W. T. Vetterling, *Numerical Recipes in Pascal*, The Art Scientific Computing, Cambridge University Press, New York, 1992.
24. J. Tetteh, E. Metcalfe, and S. Howells, *Chem. Intell. Lab. Syst.* **32** (1996) 177–191.
25. R. Tribshirani, *Neural Comput.* **8** (1996) 152–163.
26. P. Devika and L. Achenie, *J. Intell. Fuzzy Syst.* **3** (1995) 287–294.

SAŽETAK

Uporaba umjetnih neuronskih mreža za retencijsko modeliranje u ionskoj kromatografiji

Goran Srećnik, Željko Debeljak, Štefica Cerjan-Stefanović, Tomislav Bolanča, Milko Novič, Katica Lazarić i Željka Gumhalter-Lulić

Svrha rada je razvoj empirijskog modela za retencijsko modeliranje anorganskih aniona (fluorida, klorida, nitrita, sulfata, nitrata, bromida i fosfata) u suprimiranoj ionskoj kromatografiji s hidroksid-selektivnom stacionarnom fazom, i to uporabom umjetne neuronske mreže. Unaprijedna neuronska mreža s tri sloja, obučavana Levenberg-Marquardt-ovim algoritmom s povratnim rasprostiranjem pogreške te prilagodbom parametara mreže nakon prolaska čitavog skupa za obuku kroz mrežu, uporabljena je za modeliranje retencijskog mehanizma anorganskih aniona, s obzirom na parametre mobilne faze. Broj neurona u skrivenom sloju neuronske mreže i broj iteracijskih koraka optimiran je da bi se dobio što bolji retencijski model. Pokazano je da optimirana neuronska mreža omogućuje vrlo točan i brz postupak za modeliranje linearnih i nelinearnih ovisnosti te je primjenjiva za modeliranje retencije. To je dokazano razvijanjem modela retencije, uporabom neuronske mreže sa srednjom vrijednošću relativnih pogrešaka od 0,88%, uz korištenje 300 iteracijskih koraka.

TABLE I

Experimental data set used for retention modelling procedure. Dependence of retention times of analysed ions (fluoride, chloride, nitrite, sulphate, bromide, nitrate, and phosphate) on ion chromatographic analysis conditions (eluent flow rate and concentration of potassium hydroxide in eluent). All retention times data (columns 3 to 5) are logarithmically transformed (\log_{10}).

eluent flow rate mL/min	c(OH ⁻) in eluent / mmol/L	F ⁻ / min	Cl ⁻ / min	NO ₂ ⁻ / min	SO ₄ ²⁻ / min	Br ⁻ / min	NO ₃ ⁻ / min	PO ₄ ³⁻ / min
1.05	25.00	0.76	1.01	1.09	1.34	1.36	1.40	1.85
1.15	25.00	0.73	0.98	1.06	1.31	1.32	1.37	1.81
1.25	25.00	0.71	0.95	1.03	1.28	1.28	1.33	1.77
1.35	25.00	0.69	0.92	1.00	1.24	1.25	1.30	1.74
1.45	25.00	0.67	0.90	0.98	1.21	1.23	1.27	1.71
1.55	25.00	0.66	0.88	0.96	1.19	1.20	1.24	1.68
1.65	25.00	0.64	0.86	0.93	1.16	1.17	1.22	1.65
1.75	25.00	0.62	0.83	0.91	1.13	1.15	1.19	1.61
1.85	25.00	0.61	0.81	0.89	1.12	1.12	1.17	1.58
1.95	25.00	0.60	0.80	0.87	1.10	1.10	1.15	1.56
1.10	30.00	0.72	0.96	1.04	1.23	1.29	1.34	1.66
1.20	30.00	0.70	0.93	1.01	1.19	1.25	1.31	1.62
1.30	30.00	0.68	0.90	0.98	1.16	1.22	1.27	1.58
1.40	30.00	0.66	0.88	0.96	1.13	1.19	1.25	1.55
1.50	30.00	0.64	0.85	0.92	1.10	1.15	1.20	1.50
1.60	30.00	0.63	0.83	0.91	1.08	1.14	1.19	1.50
1.70	30.00	0.61	0.81	0.89	1.06	1.11	1.16	1.46
1.80	30.00	0.60	0.79	0.87	1.03	1.09	1.14	1.44
1.90	30.00	0.59	0.78	0.85	1.01	1.07	1.12	1.41
1.05	32.00	0.73	0.95	1.03	1.19	1.26	1.32	1.58
1.15	32.00	0.70	0.92	0.99	1.15	1.23	1.28	1.54
1.25	32.00	0.68	0.89	0.97	1.12	1.19	1.25	1.50
1.35	32.00	0.66	0.86	0.94	1.09	1.16	1.22	1.47
1.45	32.00	0.65	0.84	0.92	1.07	1.14	1.19	1.44
1.55	32.00	0.63	0.82	0.89	1.04	1.11	1.16	1.42
1.65	32.00	0.62	0.80	0.87	1.02	1.09	1.14	1.39
1.75	32.00	0.60	0.78	0.85	0.99	1.06	1.11	1.35
1.85	32.00	0.59	0.76	0.83	0.97	1.03	1.08	1.33
1.95	32.00	0.58	0.75	0.81	0.95	1.02	1.07	1.30

eluent flow rate mL/min	c(OH ⁻) in eluent / mmol/L	F ⁻ / min	Cl ⁻ / min	NO ₂ ⁻ / min	SO ₄ ²⁻ / min	Br ⁻ / min	NO ₃ ⁻ / min	PO ₄ ³⁻ / min
1.00	34.00	0.74	0.96	1.04	1.18	1.28	1.33	1.57
1.10	34.00	0.71	0.93	1.01	1.15	1.25	1.30	1.53
1.20	34.00	0.69	0.90	0.98	1.11	1.21	1.26	1.48
1.30	34.00	0.67	0.87	0.95	1.08	1.18	1.23	1.45
1.40	34.00	0.65	0.85	0.92	1.05	1.15	1.20	1.42
1.50	34.00	0.63	0.82	0.89	1.02	1.11	1.16	1.37
1.60	34.00	0.62	0.81	0.88	1.00	1.10	1.15	1.36
1.70	34.00	0.60	0.79	0.86	0.98	1.07	1.12	1.33
1.80	34.00	0.59	0.77	0.84	0.96	1.05	1.10	1.31
1.90	34.00	0.58	0.75	0.82	0.94	1.03	1.08	1.28
1.05	36.00	0.71	0.92	1.00	1.11	1.22	1.28	1.46
1.15	36.00	0.69	0.89	0.97	1.08	1.19	1.24	1.42
1.25	36.00	0.67	0.86	0.94	1.04	1.16	1.21	1.38
1.35	36.00	0.65	0.84	0.91	1.02	1.13	1.18	1.35
1.45	36.00	0.64	0.82	0.89	0.99	1.10	1.15	1.32
1.55	36.00	0.62	0.80	0.87	0.97	1.07	1.12	1.30
1.65	36.00	0.61	0.78	0.85	0.95	1.05	1.10	1.27
1.75	36.00	0.59	0.76	0.82	0.92	1.02	1.07	1.24
1.85	36.00	0.58	0.74	0.80	0.90	1.00	1.05	1.21
1.95	36.00	0.57	0.73	0.79	0.88	0.98	1.03	1.19
1.00	38.00	0.73	0.94	1.01	1.11	1.25	1.30	1.45
1.10	38.00	0.70	0.90	0.98	1.08	1.21	1.26	1.41
1.20	38.00	0.68	0.88	0.95	1.04	1.18	1.23	1.37
1.30	38.00	0.66	0.85	0.92	1.01	1.15	1.20	1.34
1.40	38.00	0.64	0.83	0.90	0.99	1.12	1.17	1.30
1.50	38.00	0.62	0.80	0.87	0.96	1.08	1.12	1.26
1.60	38.00	0.61	0.79	0.86	0.94	1.07	1.12	1.25
1.70	38.00	0.59	0.76	0.83	0.92	1.04	1.09	1.22
1.80	38.00	0.58	0.75	0.81	0.90	1.02	1.07	1.20
1.90	38.00	0.58	0.73	0.80	0.87	1.00	1.05	1.17
1.05	40.00	0.71	0.90	0.97	1.05	1.19	1.24	1.35
1.15	40.00	0.68	0.87	0.94	1.02	1.16	1.21	1.31
1.25	40.00	0.66	0.84	0.91	0.99	1.13	1.17	1.28
1.35	40.00	0.64	0.82	0.89	0.96	1.10	1.14	1.24
1.45	40.00	0.63	0.80	0.86	0.94	1.07	1.12	1.22

eluent flow rate mL/min	c(OH ⁻) in eluent / mmol/L	F ⁻ / min	Cl ⁻ / min	NO ₂ ⁻ / min	SO ₄ ²⁻ / min	Br ⁻ / min	NO ₃ ⁻ / min	PO ₄ ³⁻ / min
1.55	40.00	0.61	0.78	0.84	0.92	1.04	1.09	1.19
1.65	40.00	0.60	0.76	0.82	0.89	1.02	1.07	1.17
1.75	40.00	0.58	0.74	0.80	0.87	0.99	1.04	1.14
1.85	40.00	0.57	0.72	0.78	0.85	0.97	1.02	1.11
1.95	40.00	0.56	0.71	0.77	0.83	0.96	1.00	1.09
1.00	42.00	0.72	0.91	0.99	1.05	1.22	1.27	1.35
1.10	42.00	0.69	0.88	0.96	1.02	1.18	1.23	1.31
1.20	42.00	0.67	0.86	0.93	0.99	1.15	1.20	1.27
1.30	42.00	0.65	0.83	0.90	0.96	1.11	1.16	1.24
1.40	42.00	0.63	0.81	0.88	0.93	1.09	1.14	1.21
1.50	42.00	0.61	0.78	0.84	0.90	1.05	1.09	1.16
1.60	42.00	0.60	0.77	0.83	0.89	1.04	1.09	1.15
1.70	42.00	0.59	0.75	0.81	0.87	1.01	1.06	1.13
1.80	42.00	0.58	0.73	0.79	0.85	0.99	1.04	1.10
1.90	42.00	0.56	0.72	0.78	0.83	0.97	1.01	1.08
1.05	44.00	0.70	0.88	0.95	1.00	1.16	1.21	1.26
1.15	44.00	0.67	0.85	0.92	0.97	1.13	1.18	1.22
1.25	44.00	0.66	0.82	0.89	0.94	1.10	1.14	1.19
1.35	44.00	0.64	0.80	0.87	0.91	1.07	1.11	1.15
1.45	44.00	0.62	0.78	0.84	0.89	1.04	1.09	1.13
1.55	44.00	0.61	0.76	0.82	0.87	1.02	1.06	1.11
1.65	44.00	0.59	0.74	0.80	0.85	0.99	1.04	1.08
1.75	44.00	0.58	0.72	0.78	0.82	0.97	1.01	1.05
1.85	44.00	0.57	0.71	0.76	0.80	0.95	0.99	1.03
1.95	44.00	0.55	0.69	0.75	0.79	0.93	0.97	1.01
1.10	46.00	0.68	0.86	0.92	0.96	1.13	1.18	1.19
1.20	46.00	0.66	0.84	0.91	0.94	1.12	1.17	1.18
1.30	46.00	0.64	0.81	0.88	0.91	1.09	1.14	1.15
1.40	46.00	0.63	0.79	0.86	0.89	1.06	1.11	1.12
1.50	46.00	0.61	0.76	0.83	0.86	1.02	1.07	1.08
1.60	46.00	0.60	0.75	0.82	0.85	1.01	1.06	1.07
1.70	46.00	0.58	0.73	0.79	0.82	0.99	1.03	1.04
1.80	46.00	0.57	0.72	0.78	0.81	0.97	1.01	1.02
1.90	46.00	0.56	0.70	0.76	0.79	0.95	0.99	1.00
1.00	50.00	0.70	0.88	0.95	0.97	1.16	1.19	1.21

eluent flow rate mL/min	c(OH ⁻) in eluent / mmol/L	F ⁻ / min	Cl ⁻ / min	NO ₂ ⁻ / min	SO ₄ ²⁻ / min	Br ⁻ / min	NO ₃ ⁻ / min	PO ₄ ³⁻ / min
1.10	50.00	0.68	0.85	0.92	0.93	1.13	1.15	1.18
1.20	50.00	0.66	0.82	0.89	0.90	1.09	1.11	1.14
1.30	50.00	0.64	0.80	0.86	0.87	1.07	1.08	1.11
1.40	50.00	0.62	0.78	0.84	0.85	1.04	1.05	1.08
1.50	50.00	0.60	0.75	0.81	0.82	1.00	1.01	1.05
1.60	50.00	0.59	0.74	0.80	0.81	0.99	1.00	1.03
1.70	50.00	0.58	0.72	0.78	0.79	0.96	0.98	1.01
1.80	50.00	0.57	0.70	0.76	0.77	0.94	0.95	0.99
1.00	55.00	0.66	0.70	0.86	0.93	1.11	1.14	1.18
1.10	55.00	0.67	0.83	0.89	0.90	1.07	1.10	1.15
1.20	55.00	0.65	0.81	0.86	0.87	1.03	1.07	1.11
1.30	55.00	0.63	0.78	0.83	0.84	1.00	1.04	1.08
1.40	55.00	0.62	0.76	0.82	0.82	0.98	1.01	1.05
1.50	55.00	0.60	0.73	0.79	0.79	0.94	0.98	1.02
1.60	55.00	0.59	0.73	0.77	0.78	0.93	0.97	1.01
1.05	58.00	0.68	0.83	0.87	0.89	1.03	1.09	1.13
1.15	58.00	0.66	0.80	0.84	0.86	0.99	1.05	1.10
1.25	58.00	0.64	0.78	0.82	0.84	0.97	1.02	1.06
1.35	58.00	0.62	0.76	0.79	0.81	0.93	1.00	1.04
1.45	58.00	0.60	0.74	0.77	0.79	0.91	0.97	1.01
1.55	58.00	0.59	0.72	0.76	0.77	0.89	0.94	0.98
1.65	58.00	0.57	0.70	0.74	0.75	0.87	0.92	0.96
1.00	60.00	0.69	0.85	0.89	0.91	1.04	1.11	1.16
1.10	60.00	0.67	0.82	0.86	0.88	1.00	1.08	1.12
1.20	60.00	0.65	0.79	0.83	0.85	0.97	1.05	1.09
1.30	60.00	0.63	0.77	0.80	0.83	0.94	1.02	1.06
1.40	60.00	0.61	0.75	0.78	0.80	0.92	0.99	1.03
1.50	60.00	0.59	0.72	0.75	0.78	0.88	0.96	1.00
1.60	60.00	0.58	0.71	0.74	0.77	0.87	0.94	0.98